



Main Features:

- Material: Stainless steel
- Rated Capacities: 30t-50t
- OIML R60, NTEP HB44, CPA, CE and RoHS certified
- IP Rating: IP68, IP69K
- Suitable for truck scales, heavy duty hopper scales, force measurement equipment.
- High precision by OIML R60 C4, high reliability

Product description:

The P520S is a typical high precision canister compression load cell with double-cut faces against rotation. The P520S is fully hermetically sealed with stamped integrated canister; which enable it to work in the harshest conditions. A rocker column design ensures optimum weighing accuracy when subjected to off-center and side forces when the scale deck is moving back and forth, meanwhile left and right.

Dimensions (mm&inch):

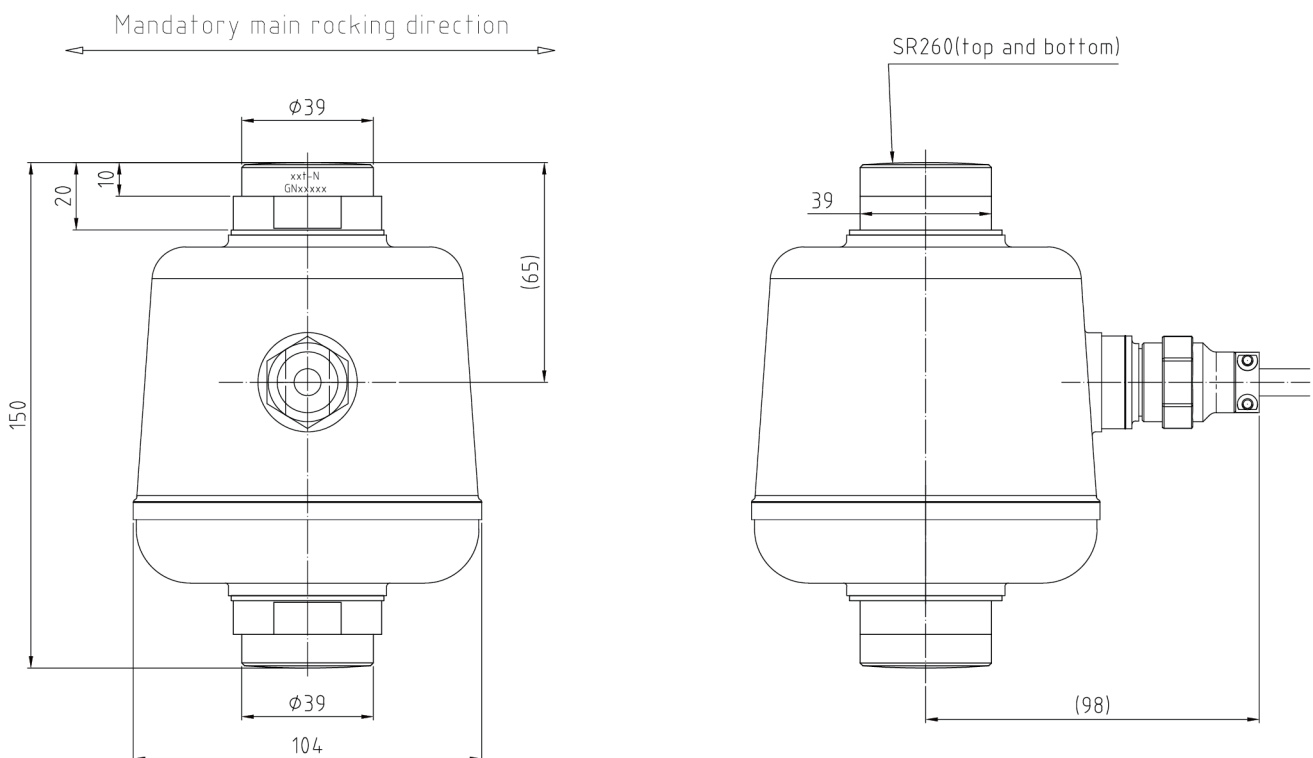

P520S Self-restoring Rockerpin Load Cell Specifications

Parameter		Units	Specifications	
Model No.			P520S	
Rated capacity (E _{max})		t	30 / 40 / 50	
Accuracy class ¹⁾²⁾			C3	C4
Min. dead load		kg	0	
Rated output		mV/V	2.0 ± 0.002	
Zero balance		% of E _{max}	± 1	
Repeatability error		% of AL ³⁾	< ± 0.010	< ± 0.005
Creep; 30 minute		% of AL	< ± 0.017	< ± 0.0125
Min. dead load output return (DR); 30 min		% of AL	< ± 0.017	< ± 0.0125
Temp. effect on	Min. dead load output	% of E _{max} /°C	< ± 0.0018	< ± 0.0014
	Rated output ²⁾	% of AL/°C	< ± 0.0012	< ± 0.0009
Temperature range	Compensated	°C(°F)	-10 to +40 [+14 to +104]	
	Operating		-40 to +65 [-40 to +149]	
	Safe storage		-40 to +80 [-40 to +176]	
Excitation voltage	Recommended	V AC/DC	5 ~ 15	
	Maximum		15	
Terminal resistance	Excitation	Ω	1100 ± 15	
	Output		1000 ± 3	
Insulation resistance @50VDC		MΩ	> 5000	
Breakdown voltage		V AC	> 500	
Seal type / IP rating			Hermetically welded / IP68 69K	
Load limit	Safe	% of E _{max}	150	
	Ultimate		300	
Material	Spring element		Stainless steel	
	Enclosure		304 stainless steel, laser welded	
	Anti-Rotation		Integral; Parallel dual-plane	
	Strain gauge		PEEK-1000	
	Cable construction		Exterior braided armor covered with fire-retardant PVC; PVC chemically resistant jacket, 7mm O.D. ; 4 Conductors triple shielded wires	
Cable length		m	16.0	
Weight; approx		kg	6.0	
Fatigue life		cycles @E _{max}	> 1,000,000	
Deflection at E _{max} ; approx		mm	< 0.7	
Barometric pressure effect on Zero Output		Vmin/kPa	< 1.0	

Notes:

¹⁾ Error due to the combined effect of non-linearity and hysteresis

²⁾ The sum of errors due to Temperature Effect on Output comply with the requirements of OIML R60 and NIST HB44

³⁾ AL = Applied Load

Cable Colour Code: 4-wire [Optional: 6-wire]

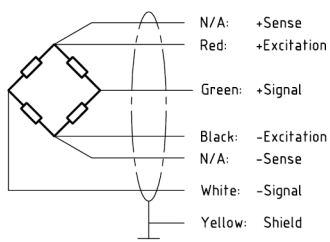

Shield connected to load cell body

Interchangeable Products:

Manufacturer	Model
Mettler-Toledo	GD
Flintec	RC3